

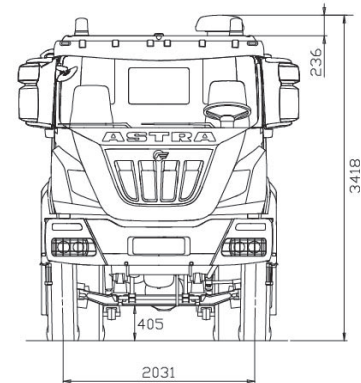
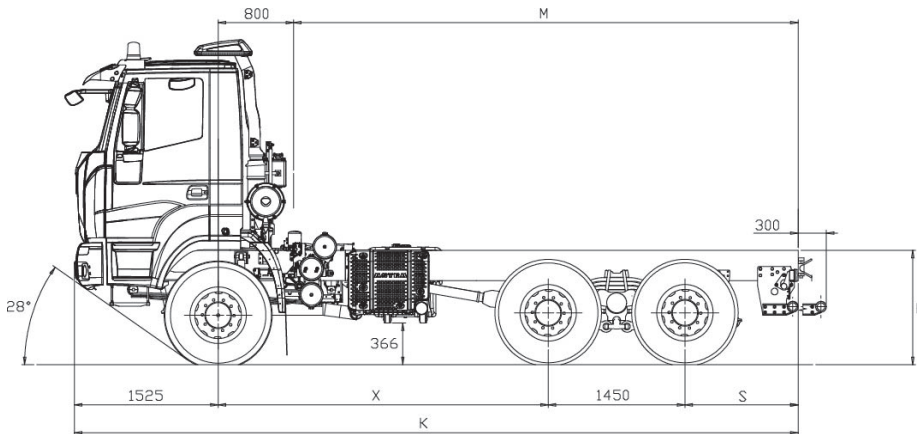

**chassis 6x4
HD64.45**

DIMENSIONS (MM)

X	K	M max(*)	S	H		TURNING DIAMETER (wall to wall)
				unloaded	loaded	
3500	7675	5350	1200	1200	1130	19500
3800	7975	5650	1200	1200	1130	20500
4500	8675	6350	1200	1200	1130	22700

(*) M max.: indicative value to be confirmed by bodybuilder
(Tyres 13R22.5)

WEIGHTS (KG)

X	Distribution net weight(*)			Max technical weight			
	First axle	Rear axles	Net Weight	First axle	Rear axles	Gross Vehicle Weight	Gross Combination Weight
3500	5391	4930	10321	8000 9000 (1) (2)	32000 (2)	40000 (2)	104000
3800	5511	4895	10356				
4500	5720	4695	10415				

(*) Net weight including driver with tanks filled to at least 90%, equipped with standard equipment according to the manufacturer's specifications and, if fitted, the mass of the bodywork, spare wheels and tool box.

(1) With tyres on front axles 385/65R22.5 or 325/95R24 and reinforced springs (OPT).

(2) With tyres 325/95R24 or max speed limited to 70Km/h depending on pneus type and brand.

Higher speeds are allowed with load reductions subject to Astra technical office approval.

Other tyres available, subject to Astra technical office approval.



ENGINES

CURSOR 13 turbo intercooler electronic common rail with Hi-eSCR system. 6 in-line cylinders. Single block head, four valves per cylinder, light alloy pistons. Total displacement: 12.882 cm³. Bore for stroke: 135 x 150 mm. Water cooling. Dry air filter with safety cartridge.

Max.power(EEC) 450 KW (332 HP) @ 1900 rpm
Max.torque(EEC) 2200 Nm (224 kgm) @ 970 - 1440 rpm
Turbine EVGT



GEARBOX

Manual gearbox, **ZF 16S2220TO** Ecosplit 4 technology with servoshift, 16 synchronised forward speeds + 2 reverse.

On request: Automated ZF AS-Tronic **16AS2630TO**.

Gearbox model	Rear axle ratio	Speed [kph] calculated at maximum power rpm																	
		Gears / Gear ratios																	
		1st	2nd	3rd	4th	5th	6th	7th	8th	9th	10th	11th	12th	13th	14th	15th	16th	rev. 1st	rev. 2nd
16AS 2630 TO		14.12	11.68	9.54	7.89	6.52	5.39	4.57	3.78	3.09	2.56	2.09	1.73	1.43	1.18	1	.83	13.07	10.81
	5.01	5.50	6.64	8.13	9.83	11.90	14.40	16.98	20.53	25.11	30.31	37.13	44.85	54.26	65.76	77.59	93.49*	5.94	7.18
16S 2220 TO		13.8	11.54	9.49	7.93	6.53	5.46	4.57	3.82	3.02	2.53	2.08	1.74	1.43	1.2	1.00	.84	12.92	10.8
	5.01	5.62	6.72	8.18	9.78	11.88	14.21	16.98	20.31	25.69	30.67	37.30	44.59	54.26	64.66	77.59	92.37*	6.01	7.18

(*) Max limited speed 90 km/h. Other speeds available, subject to the Astra technical office approval.



CLUTCH

Single dry plate, diameter 17". Pull type engagement with diaphragm spring. Hydro-pneumatic power steering engagement control, with driven disk wear recovery slave cylinder.



AXLES

FRONT

Steering, hot moulding in high tensile steel. Wheel stud protection.

REAR

Double drive axles. Double reduction: crown wheel and pinion centrally and epicyclic group in wheel hubs. 2nd axle with torque distributor to the two rear axles. Lockable differentials from driver seat. Tandem assembled to the chassis by reaction rods with silentblock.

On request:

Rear-axle ratio 1:4,229
Rear-axle ratio 1:5,009
Rear-axle ratio 1:5,558
Rear-axle ratio 1:6,095
Rear-axle ratio 1:6,588



SUSPENSIONS

FRONT

1st axle, parabolic springs, n° 4 leaves 24x90 mm, with hydraulic shock absorbers. Standard stabilizer bar.

On request:

Reinforced parabolic springs, n° 5 leaves 24x90 mm. Mandatory with 9 t axle load.

REAR

Parabolic springs, swivelling on central pin: n° 4 leaves 40x100 mm.

On request:

Stabilizer bar on 2nd axle. Stabilizer bar on 3rd axle.

Extra-reinforced conventional springs, n° 10 leaves 25x100 mm.



CHASSIS

Special steel with high tensile strength limit, two flat and parallel side members (width 820 mm.), C section (320x90x10mm), cross members bolted to the frame. R.B.M. (Rail Bending Moment): 202.020 Nm (20.593 Kg.m.). Steel front bumpers with headlamp protection grids, front manoeuvring hook, rear underrun bar, steel fuel tank capacity 300 litres.



STEERING

ZF 8098 quadrilateral power steering on front axle wheels with variable ratio 1:22.2/1:26.2 with auxiliary cylinder. Circuit with main hydraulic pump on engine and emergency pump on gearbox. Steering rods with self-lubricating joints. Height and inclination pneumatic adjustable steering column.



TYRES

FRONT: 13R22,5 156/150 G Single tubeless

REAR: 13R22,5 156/150 G Twin tubeless

Spare wheel on the chassis.

Other Possible combinations:

315/80 R22,5 156/150K

385/65 R22,5 160J (*) + 315/80 R22,5 156/150K

325/95 R24 162/160K (*)

(*) Mandatory with 9 ton front axle load.

Other tyres available, subject to Astra technical office approval.



BRAKES

Front and rear "duo-duplex" self-adjusting wedge type brakes with automatic play take-up.

Total net braking surface 9.276 cm². ABS + EBL.

Service brake: Pedal controlled air brake, acting on all wheels. Solo vehicles, two independent circuits, one for 1st axle, one for 2nd and 3rd axle; 1st category wheels anti-lock system.

Towing vehicles, three independent circuits, one for 1st axle, one for 2nd and 3rd axle and another for the trailer.

Emergency brake: Incorporated in service brake.

Parking brake: Manual spring-type mechanical with pneumatic control acting on 2nd and 3rd axle wheels.

IVECO SUPER ENGINE BRAKE: braking power 463 kW (621 HP).

On request:

Hydraulic intarder.

OFF/ROAD button for excluding ABS for speed 15 kph.



ELECTRICAL SYSTEM

Voltage: 24 V

Alternator generator 90 A - 28 V (2520 W).

Accumulators: 2 in series, 180 Ah.

Starter motor 24 V 5,5 kW.

Mechanically controlled electrical circuit breaker.



CAB

White cab built in galvanized pressed steel with hydraulic tilting up to 60°. Cab suspension with 4 helicoidal springs with coaxial shock absorbers and integrated dampers, antiroll bar and end-of-stroke pads. Tinted electric door windows. Internal panels completely washable and fireproof. Rapid pneumatic connection for cab cleaning. 4-speed ventilation and heating system with air recirculation system. Air suspended 3-way adjustable driver seat with seat belts. Mechanical passenger seat with seat belts.