

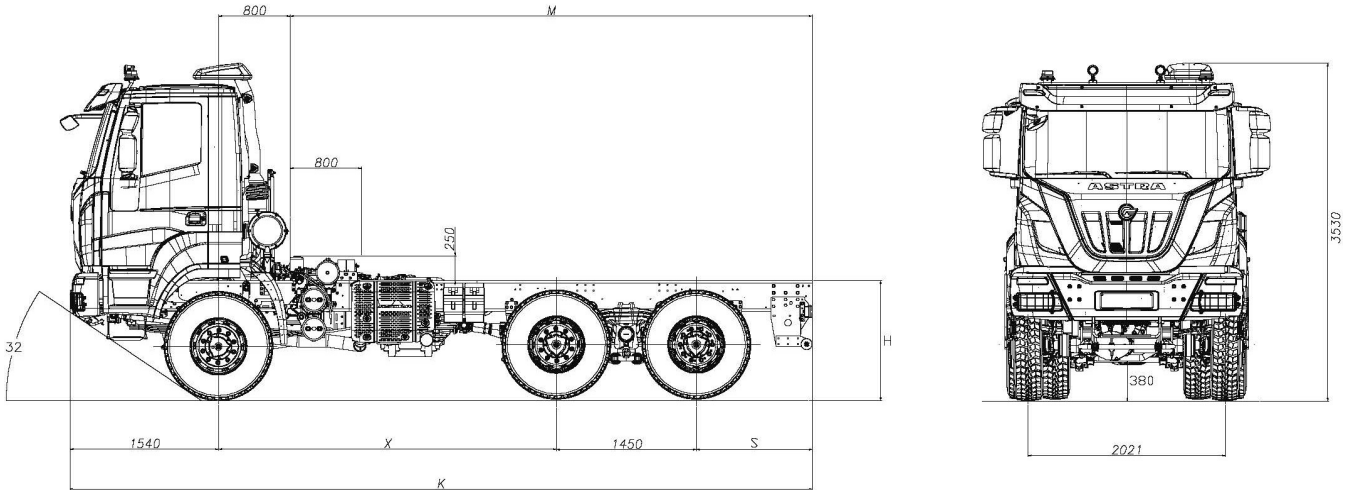

**chassis 6x6  
HD66.50**

**DIMENSIONS (MM)**

X	K	M max(*)	S	H		TURNING DIAMETER (wall to wall)
				unloaded	loaded	
3500	7675	5350	1200	1270	1205	19500
3800	7975	5650	1200	1270	1205	20500
4100	8275	5950	1200	1270	1205	21400
4500	8675	6350	1200	1270	1205	22700

(\*) M max: indicative value to be confirmed by bodybuilder  
Tyres I3 R22.5

**WEIGHTS (KG)**

X	Distribution net weight(*)			Max technical weight			
	First axle	Rear axles	Net Weight	First axle	Rear axles	Gross Vehicle Weight	Gross Combination Weight
3500	5740	5110	10850	8000 9000 (1) (2)	32000 (2)	40000 (2)	104000
3800	5875	5010	10885				
4100	5990	4930	10920				
4500	6130	4835	10965				

(\*) Net weight including driver with tanks filled to at least 90%, equipped with standard equipment according to the manufacturer's specifications and, if fitted, the mass of the bodywork, spare wheels and tool box.

(1) With tyres on front axle 385/65R22.5 or 325/95R24 and reinforced springs (OPT).

(2) With tyres 325/95R24 or max speed limited to 70Km/h depending on tyre type and brand.

Higher speeds are allowed with load reductions subject to Astra technical office approval.  
Other tyres available, subject to Astra technical office approval.



## ENGINES

**CURSOR 13** turbo intercooler electronic common rail with Hi-eSCR system. 6 in-line cylinders. Single block head, four valves per cylinder, light alloy pistons. Total displacement: 12.882 cm<sup>3</sup>. Bore for stroke: 135 x 150 mm. Water cooling. Dry air filter with safety cartridge.

Max.power(EEC)	368 KW (500 HP) @ 1900 rpm
Max.torque(EEC)	2300 Nm (235 kgm) @ 970 - 1525 rpm
Turbine	VGT(Variable Geometry Turbocharger)



## GEARBOX

Manual gearbox **ZF 16S2520TO** Ecosplit 4 technology with servoshift, 16 synchronised forward speeds + 2 reverse.

**On request:**

Automated ZF AS-Tronic **16AS2630TO**.

		Speed [kph] calculated at maximum power rpm																	
		Gears / Gear ratios																	
Gearbox model	Rear axle ratio	1st	2nd	3rd	4th	5th	6th	7th	8th	9th	10th	11th	12th	13th	14th	15th	16th	rev. 1st	rev. 2nd
<b>16AS 2630 TO</b>		14.12	11.68	9.54	7.89	6.52	5.39	4.57	3.78	3.09	2.56	2.09	1.73	1.43	1.18	1	.83	13.07	10.81
<b>Off road slow</b>	<b>5.01</b>	3.43	4.15	5.08	6.15	7.44	9.00	10.61	12.83	15.69	18.94	23.20	28.03	33.91	41.10	48.50	58.43	3.71	4.49
<b>On road fast</b>	<b>5.01</b>	5.50	6.64	8.13	9.83	11.90	14.40	16.98	20.53	25.11	30.31	37.13	44.85	54.26	65.76	77.59	93.49*	5.94	7.18
<b>16S 2520 TO</b>		13.8	11.54	9.49	7.93	6.53	5.46	4.57	3.82	3.02	2.53	2.08	1.74	1.43	1.2	1	.84	12.92	10.8
<b>Off road slow</b>	<b>5.01</b>	3.51	4.20	5.11	6.12	7.43	8.88	10.61	12.70	16.06	19.17	23.32	27.87	33.91	40.41	48.50	57.73	3.75	4.49
<b>On road fast</b>	<b>5.01</b>	5.62	6.72	8.18	9.78	11.88	14.21	16.98	20.31	25.69	30.67	37.30	44.59	54.26	64.66	77.59	92.37*	6.01	7.18

(\*) Max limited speed 90 km/h. Other speeds available, subject to the Astra technical office approval.



## CLUTCH

Single dry plate, diameter 17". Pull type engagement with diaphragm spring. Hydro-pneumatic power steering engagement control, with driven disk wear recovery slave cylinder.



## TRANSFER BOX

Mechanical with two ratios. Helical spur gears, mounted on three propeller shafts, engaged with each other. Lockable differential by pneumatic control from driver seat. Air-oil cooler. Transmission ratio 1:1 - 1:1,16. Front/rear torque distribution ratio 1:2,2



## AXLES

### FRONT

1st axle driving and steering, with double reduction: central by bevel gear, final by planetary gear in wheel hubs.

**On request:**

Cross-axle differential lock.

Reinforced front axle: max technical weight 8 ton or 9 ton (with reinforced suspension). Available axle ratio: 5,01 - 5,47 - 5,96 - 6,28.

### REAR

Two driving axles in tandem, with double reduction: central with bevel gear, final by planetary gear in wheel hubs, interaxle and cross-axle differential lock. Tandem linked to the chassis by reaction rods with silentblocks.

**On request:** Rear-axle ratio 1:4,229; 1:5,009; 1:5,558; 1:6,095; 1:6,588.



## SUSPENSIONS

### FRONT

Parabolic springs, 4 leaves 24x90 mm, with hydraulic shock absorbers. Standard stabilizer bar on 1st axle.

**On request:** Reinforced parabolic springs, 5 leaves 24x90 mm.

### REAR

Parabolic springs, swivelling on central pin: 4 leaves 40x100 mm.

**On request:**

Stabilizer bar on 2nd axle. stabilizer bar on 3rd axle.

Extra-reinforced conventional springs, 10 leaves 25x100 mm.



## CHASSIS

Special steel with high tensile strength limit, two flat and parallel side members (width 820 mm.), C section (320x90x10mm), cross members bolted to the frame. R.B.M. (Rail Bending Moment): 202.020 Nm (20.593 Kgm.). Steel front bumpers with headlamp protection grids, front manoeuvring hook, rear underrun bar, steel fuel tank capacity 300 litres.



## TYRES

**FRONT:** 13R22,5 156/150 G Single tubeless

**REAR:** 13R22,5 156/150 G Twin tubeless

Spare wheel on the chassis.

Other Possible combinations:

315/80 R22,5 156/150K ; 385/65 R22,5 160J (\*) + 315/80 R22,5 156/150K

325/95 R24 162/160K (\*)

(\*) Mandatory with 9 ton front axle load.

Other tyres available, subject to Astra technical office approval.



## BRAKES

Front and rear drum brakes, Duo-Duplex with automatic slack adjuster. ABS + EBL.

**Service brake:** Pedal controlled air brake, acting on all wheels. Solo vehicles, two independent circuits, one for 1st axle, one for 2nd and 3rd axle. Towing vehicles, three independent circuits, one for 1st axle, one for 2nd and 3rd axle and another for the trailer.

**Emergency brake:** Integrated in service brake.

**Parking brake:** Manual spring-type mechanical with pneumatic control acting on 2nd and 3rd axle wheels.

**IVECO SUPER ENGINE BRAKE:** Braking power 463 kW (621 HP).



## STEERING

ZF 8098 quadrilateral power steering on front axle wheels with variable ratio 1:22.2/1:26.2 with auxiliary cylinder. Circuit with main hydraulic pump on engine and emergency pump on gearbox. Steering rods with self-lubricating joints. Height and inclination pneumatic adjustable steering column.



## ELECTRICAL SYSTEM

Voltage: 24 V

Alternator generator 90 A - 28 V (2520 W).

Accumulators: 2 in series, 180 Ah.

Starter motor 24 V 5,5 kW.

Mechanically controlled electrical circuit breaker.



## CAB

White short cab built in galvanized pressed steel with hydraulic tilting up to 60°. Cab suspension with 4 helicoidal springs with coaxial shock absorbers and integrated dampers, anti-roll bar and end-of-stroke pads. Tinted electric door windows. Internal panels completely washable and fireproof. Rapid pneumatic connection for cab cleaning. 4-speed ventilation and heating system with air recirculation system. Air suspended 3-way adjustable driver seat with seat belts. Mechanical passenger seat with seat belts.