

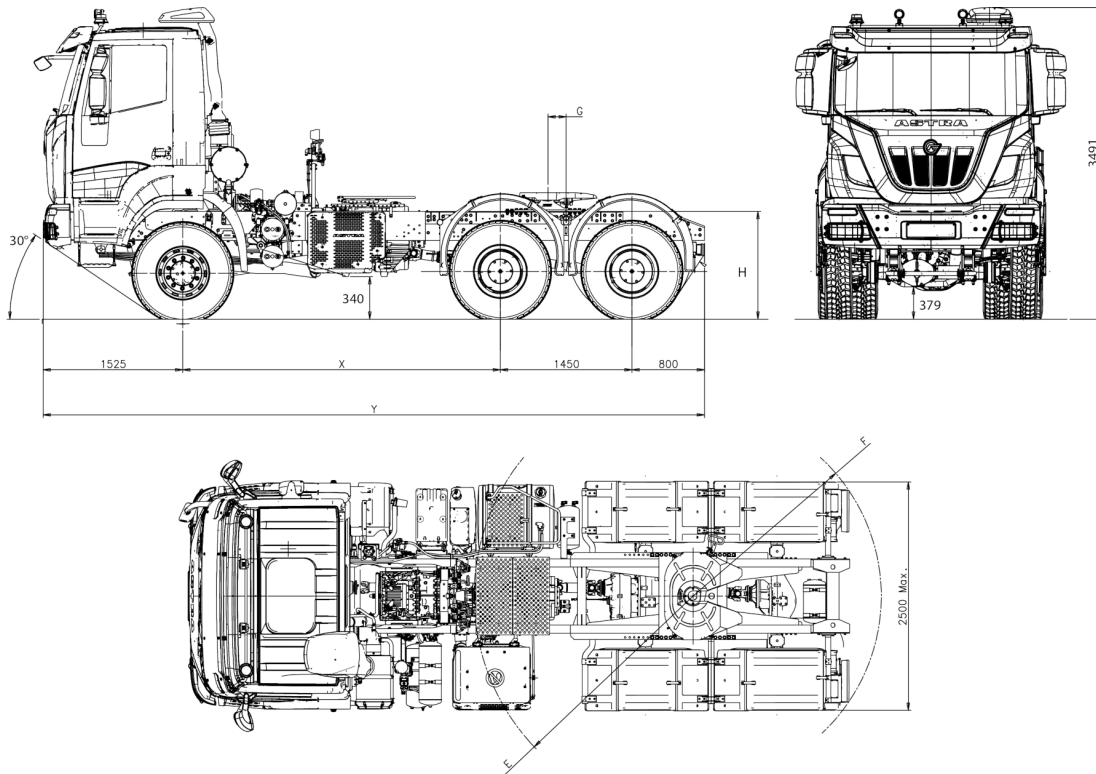

Tractor 6x6 HD66.50T



DIMENSIONS (mm)

X	K	G(1)	M max(*)	S	H		TURNING DIAMETER (wall to wall)
					unloaded	loaded	
3500	7275	300		800	1245	1182	17400

(1) Standard fifth wheel position. In case of different positioning needs, the quote may change in relation with the technical GVW of the vehicle. Values to be confirmed in combination with the semitrailer.

WEIGHTS (kg)

X	Distribution net weight(*)			Max technical weight				
	First axle	Rear axles	Net Weight	First axle	Rear axles	Weight on Fifth Wheel	Gross Vehicle Weight	Gross Combination Weight
3500	5730	5385	11115	8000 9000 (1)	32000 (2)	28885	40000 (2)	104000 130000 (3)

(*) Net weight including driver with tanks filled to at least 90%, equipped with standard equipment according to the manufacturer's specifications and, if fitted, the mass of the bodywork, spare wheels and tool box.

(1) With tyres on front axle 385/65R22.5 or 325/95R24 and reinforced springs (OPT).

(2) With tyres 325/95R24 or max speed limited to 70Km/h depending on tyre type and brand.

(3) For manual gearbox with additional parking brake air chambers. For automated gearbox check mission and configuration with Technical Dept.

The data shown are indicative and non-binding. Payload and vehicle dimension data must always be verified during final testing. Do not use the drawing in the present sheet to design the equipment. Astra reserves the right to make any changes at any time and without notice.



ENGINES

CURSOR 13 turbo intercooler electronic common rail with Hi-eSCR system. 6 in-line cylinders. Single block head, four valves per cylinder, light alloy pistons. Total displacement: 12.882 cm³. Bore for stroke: 135 x 150 mm. Water cooling. Dry air filter with safety cartridge.

Max.power(EEC)	368 KW (500 HP) @ 1900 rpm
Max.torque(EEC)	2300 Nm (235 kgm) @ 970 - 1525 rpm
Turbine	VGT(Variable Geometry Turbocharger)



GEARBOX

Manual gearbox **ZF 16S2520TO** Ecosplit 4 technology with servoshift, 16 synchronised forward speeds + 2 reverse.

On request:

Automated ZF AS-Tronic **16AS2630TO**.



CLUTCH

Single dry plate, diameter 17 ". Pull type engagement with diaphragm spring. Hydropneumatic power steering engagement control, with driven disk wear recovery slave cylinder.



TRANSFER BOX

Mechanical with two ratios. Helical spur gears, mounted on three propeller shafts, engaged with each other. Lockable differential by pneumatic control from driver seat. Air-oil cooler. Transmission ratio 1:1 - 1:1,16. Front/rear torque distribution ratio 1:2,2.



AXLES

FRONT

1st axle driving and steering, with double reduction: central by bevel gear, final by planetary gear in wheel hubs.

On request:

Cross-axle differential lock.

Reinforced front axle: max technical weight 8 ton or 9 ton (with reinforced suspension). Available axle ratio: 5,01 - 5,47 -5,96 - 6,28.

REAR

Two driving axles in tandem, with double reduction: central with bevel gear, final by planetary gear in wheel hubs, interaxle and cross-axle differential lock. Tandem linked to the chassis by reaction rods with silentblocks.

On request: Rear-axle ratio 1:4,229; 1:5,009; 1:5,558; 1:6,095; 1:6,588.



SUSPENSIONS

FRONT

Parabolic springs, 4 leaves 24x90 mm, with hydraulic shock absorbers. Standard stabilizer bar on 1st axle.

On request: Reinforced parabolic springs, 5 leaves 24x90 mm.

REAR

Parabolic springs, swivelling on central pin: 4 leaves 40x100 mm.

On request:

Stabilizer bar on 2nd axle.stabilizer bar on 3rd axle.

Extra-reinforced conventional springs, 10 leaves 25x100 mm.



CHASSIS

Special steel with high tensile strength limit, two flat and parallel side members (width 820 mm.), C section (320x90x10mm), cross members bolted to the frame. R.B.M. (Rail Bending Moment): 202.020 Nm (20.593 Kgm.). Steel front bumpers with headlamp protection grids, front manoeuvring hook, subframe, rear underrun bar, steel fuel tank capacity 300 litres. Spot and side alighting step, rubber mudguards on 2nd and 3rd axles, toolbox.

On request:

Fifth wheel



TYRES

FRONT: 13R22,5 156/150 G Single tubeless

REAR: 13R22,5 156/150 G Twin tubeless

Spare wheel on the chassis.

Other Possible combinations:

315/80 R22,5 156/150K ; 385/65 R22,5 160J (*) + 315/80 R22,5 156/150K

325/95 R24 162/160K (*)

(*) Mandatory with 9 ton front axle load.

Other tyres available, subject to Astra technical office approval.



BRAKES

Front and rear drum brakes, Duo-Duplex with automatic slack adjuster. ABS + EBL.

Service brake: Pedal controlled air brake, acting on all wheels. Solo vehicles, two independent circuits, one for 1st axle, one for 2nd and 3rd axle. Towing vehicles, three independent circuits, one for 1st axle, one for 2nd and 3rd axle and another for the trailer.

Emergency brake: Integrated in service brake.

Parking brake: Manual spring-type mechanical with pneumatic control acting on 2nd and 3rd axle wheels.



ELECTRICAL SYSTEM

Voltage: 24 V

Alternator generator 90 A - 28 V (2520 W).

Accumulators: 2 in series, 180 Ah.

Starter motor 24 V 5,5 kW.

Mechanically controlled electrical circuit breaker.



CAB

White short cab built in galvanized pressed steel with hydraulic tilting up to 60°.

Cab suspension with 4 helicoidal springs with coaxial shock absorbers and integrated dampers, anti-roll bar and end-of-stroke pads. Tinted electric door windows. Internal panels completely washable and fireproof. Rapid pneumatic connection for cab cleaning. 4-speed ventilation and heating system with air recirculation system. Air suspended 3-way adjustable driver seat with seat belts.

Mechanical passenger seat with seat belts.

The data shown are indicative and non-binding. Payload and vehicle dimension data must always be verified during final testing.

Do not use the drawing in the present sheet to design the equipment.

Astra reserves the right to make any changes at any time and without notice.