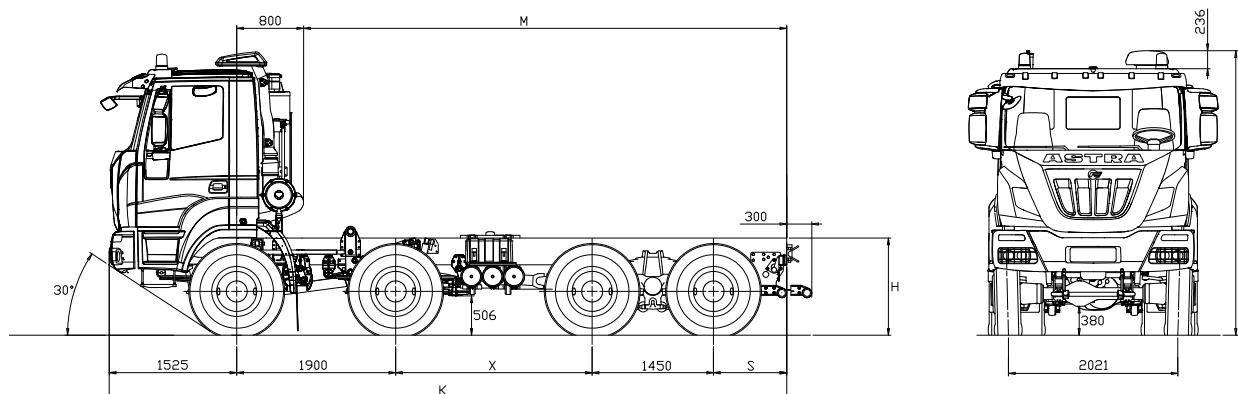

**chassis 8x6
86.44 / 86.48 / 86.54**

DIMENSIONS (mm)

X	K	M max (*)	S	S ON REQUEST	H		TURNING DIAMETER (wall to wall)
					unloaded	loaded	
2350	8425	6100	1200	875/1500	1254	1189	19800
2600	8675	6350	1200	875/1500			20600
2850	8925	6600	1200	875/1500			21400
3100	9175	6850	1200	875/1500			22200
3350	9425	7100	1200	1500			23000
3600	9975	7650	1500	-			23800
4100	10475	8150	1500	-			25400

(*) M max.: indicative value to be confirmed by bodybuilder.
(Tyres 13R22.5)

WEIGHT (kg)

X	Distribution net weight (*)				Max technical weight				
	1 st axle	2 nd axle	3 rd +4 th axle	Net weight	1 st +2 nd axle		3 rd +4 th axle	Gross Vehicle weight	Gross Combination weight
2350	3712	3277	4205	11195	16000	18000 (1) (2)	32000 (2)	50000 (2)	121.500
2600	3708	3273	4239	11220					
2850	3703	3268	4269	11240					
3100	3706	3271	4308	11285					
3350	3703	3268	4333	11305					
3600	3694	3259	4398	11350					
4100	3699	3264	4447	11410					

(*) Weight including oil, fuel, spare wheel, driver Kg.75, with 13R22.5 tyres
(1) With tyres on front axles 385/65R22.5 or 325/95R24 and reinforced springs (OPT).
(2) With tyres 325/95R24 or max speed limited to 70 Km/h depending on pneus type and brand.
 Higher speeds are allowed with load reductions subject to Astra technical office approval.
 Other tyres available, subject to Astra technical office approval.



ENGINES

CURSOR 13 turbo intercooler euro 3 diesel injection/cycle with electronic unit injection pumps. Single block head, four valves per cylinder, light alloy pistons. Total displacement: 12.882 cm³. Bore for stroke: 135 x 150 mm. 6 in-line cylinders. Water cooling. Viscostatic cooling fan. Dry air filter with safety cartridge. Vertical muffler.

	86.44	86.48	86.54
Model	CURSOR 13	CURSOR 13	CURSOR 13
Max. power (EEC)	324 kW (440 HP)	353 kW (480 HP)	397 kW (540 HP)
Corresponding rpm	1.900 rpm		
Max. torque (EEC)	2.100 Nm (214 kgm)	2.200 Nm (224 kgm)	2.350 Nm (240 kgm)
Corresponding rpm	1.000-1.440 rpm		1.000-1.690 rpm
Turbine	VGT - Variable Geometry Turbine		



GEARBOX

Manual ZF Ecosplit 4 technology gearbox with servoshift, 16 synchronised forward speeds + 2 reverse:

ZF16S2220TO: HD9 86.44

ZF16S2520TO: HD9 86.48/HD9 86.54

On request:

ZF16S2320TD: HD9 86.44/ HD9 86.48

ZF ASTRONIC 16AS2630TO: HD9 86.44/ HD9 86.48/ HD9 86.54

ALLISON HD4700: only for wheelbase>4100mm

		Speed [kph] at maximum power (*)																			
		Gears																		RM1	RM2
		1	2	3	4	5	6	7	8	9	10	11	12	13	14	15	16				
ZF 16S2220TO - ZF 16S2520TO	Gear ratios	13.80	11.54	9.49	7.93	6.53	5.46	4.57	3.82	3.02	2.53	2.08	1.74	1.43	1.20	1.00	0.84	12.92	10.80		
	Rear axle ratio with transfer 1:1.0	3.793	7.5	8.9	10.9	13.0	15.8	18.9	22.5	27.0	34.1	40.7	49.5	59.2	72.0	85.9	103.0*	122.7*	8.0	9.5	
		4.229	6.7	8.0	9.7	11.7	14.2	16.9	20.2	24.2	30.6	36.5	44.4	53.1	64.6	77.0	92.4*	110.0*	7.2	8.6	
		5.009	5.7	6.8	8.2	9.8	11.9	14.3	17.1	20.4	25.8	30.8	37.5	44.8	54.6	65.0	78.0	92.9*	6.0	7.2	
		5.558	5.1	6.1	7.4	8.9	10.8	12.9	15.4	18.4	23.3	27.8	33.8	40.4	49.2	58.6	70.3	83.7	5.4	6.5	
		6.095	4.6	5.6	6.8	8.1	9.8	11.7	14.0	16.8	21.2	25.3	30.8	36.8	44.8	53.4	64.1	76.3	5.0	5.9	
		6.588	4.3	5.1	6.3	7.5	9.1	10.9	13.0	15.5	19.6	23.4	28.5	34.1	41.5	49.4	59.3	70.6	4.6	5.5	
	Gear ratios	13.80	11.54	9.49	7.93	6.53	5.46	4.57	3.82	3.02	2.53	2.08	1.74	1.43	1.20	1.00	0.84	12.92	10.80		
	Rear axle ratio with transfer 1:1.6	3,793	4.7	5.6	6.8	8.1	9.9	11.8	14.1	16.9	21.3	25.5	31.0	37.0	45.0	53.7	64.4	76.7	5.0	6.0	
		4,229	4.2	5.0	6.1	7.3	8.8	10.6	12.6	15.1	19.1	22.8	27.8	33.2	40.4	48.1	57.8	69.0	4.5	5.4	
		5,009	3.5	4.2	5.1	6.1	7.5	8.9	10.7	12.8	16.1	19.3	23.4	28.0	34.1	40.6	48.8	58.0	3.8	4.5	
		5,558	3.2	3.8	4.6	5.5	6.7	8.0	9.6	11.5	14.6	17.4	21.1	25.3	30.7	36.6	43.9	52.3	3.4	4.1	
6,095		2.9	3.5	4.2	5.1	6.1	7.3	8.8	10.5	13.3	15.8	19.3	23.0	28.0	33.4	40.1	47.7	3.1	3.7		
6,588		2.7	3.2	3.9	4.7	5.7	6.8	8.1	9.7	12.3	14.7	17.8	21.3	25.9	30.9	37.1	44.1	2.9	3.4		

(*) Max limited speed 90 km/h. Other speeds available, subject to the Astra technical office approval.



P.T.O.

On request:

Gearbox	ZF16S2220TO-ZF16S2520TO	Mx. Torque	Application
P.T.O.	Ratio	Nm	
ZF NH/1b	0,91/1,09:1	1000	For tipping unit pumps, pumps for cranes, ecc.
ZF NH/1c	0,91/1,09:1	1000	For tipping unit pumps, unit pumps for concrete, pumps for cranes, ecc.
ZF NH/4c	1,17/1,40:1	430	For tipping unit pumps.
ZF N221/10B-PL + NL/1c	1,75/2,09:1+0,91/1,09:1	560+600	double PTO for concrete pumps

ZF NMV 221 Power take-off (ratio 1,55:1) max available torque 1300 Nm for concrete pumps.

ZF NMV 221 Power take-off (ratio 0,98:1) max available torque 2000 Nm for concrete pumps.

Multipower power take-off (ratio 1,29:1) max available torque 900 Nm for concrete mixers.

Parker Chelsea 870 XAF power take-off (ratio 1,67:1) max available torque 908 Nm for Allison gearbox.

Parker Chelsea 870 XBF power take-off (ratio 1,56:1) max available torque 854 Nm for Allison gearbox.



CLUTCH

Single dry plate, diameter 17". Pull type engagement with diaphragm spring.

Hydro-pneumatic power steering engagement control, with driven disc wear recovery slave cylinder.

On request: Ceramic clutch 17".



TRANSFER BOX

Mechanical with two ratios. Helical spur gears, mounted on three shafts, engaged with each other. Lockable differential by pneumatic control from driver seat.

	440 / 480 HP	540 HP
Model	IVECO TC2200	STEYR VG2700
Transmission ratio	1:1 - 1:1,6	1:0,913 - 1:1,407
Front/rear torque distribution ratio	1:2,2	1:2,6



AXLES

FRONT

1st axle, driving and steering, in cast iron with double reduction, central by bevelled pair, lateral by epicyclic group in wheel hubs.

2nd axle in high tensile pressed steel, steering, not driving.

Wheel stud protection.

On request: Lockable differential by pneumatic control from driver seat.

Kessler front axle:

Version	Max technical weight on 1 st axle (ton)	Available axle ratio
HD9 K	8 t	5,01 - 5,47 - 5,96 - 6,28
	9 (with reinforced suspension)	

REAR:

Two drive axles in tandem. Double reduction: central with beveled pair, final in the wheel hubs by means of epicycloidal assembly. Torque distribution between the axles by means of a distributor fitted on the intermediate axle. Differential lockable from driver seat. Tandem assembled to the chassis by reaction rods with silentblocks.

On request:

Rear-axle ratio 1:3.793

Rear-axle ratio 1:4.229

Rear-axle ratio 1:5.009

Rear-axle ratio 1:5.558

Rear-axle ratio 1:6.095

Rear-axle ratio 1:6.588



SUSPENSIONS

FRONT

Parabolic springs, n° 3 leaves 26x90 mm, hydraulic shock absorbers. Standard stabilizer bar on 1st axle.

On request:

Stabilizer bar on 2nd axle.

Reinforced parabolic springs, n° 4 leaves 26x90 mm (mandatory with 9t version).

REAR

Parabolic springs, swiveling on central pin: n° 4 leaves 40x100mm, torque bars and stiffening brackets.

Standard stabilizer bar on 4th axle.

On request:

Stabilizer bar on 3rd axle.

Extra-reinforced conventional springs, n° 10 leaves 25x100 mm.



CHASSIS

Special steel with high tensile strength limit, two flat and parallel side members (width 820 mm.), C section (320x90x10mm), cross members bolted to the frame. R.B.M. (Rail Bending Moment): 202.020 Nm (20.593 Kgm.).

Steel front bumpers with headlamp protection grids, front maneuvering hook, rear underrun bar, rubber mud-guard 2nd axle, steel fuel tank capacity 300 litres.

On request:

Rapid pneumatic connection for tyres inflation.

Rear underrun bar in set back position.

Extra-long underrun bar for concrete mixer.

Rear maneuvering hook.

Rear automatic towing hook.

Rubber mudguards on 3rd and 4th axle.

Side winch for spare wheel (wheelbase 2350 and 2850 excluded).



TYRES

FRONT: 13R22.5 156/150 G Single tubeless

REAR: 13R22.5 156/150 G Twin tubeless

Spare wheel on the chassis.

Other Possible combinations:

TYRES	ASSEMBLY	
	FRONT	REAR
12.00R20 156/150G	S	D
315/80R22.5 156/150K		
385/65R22.5 160J (*)	S	
315/80R22.5 156/150K		D
325/95R24 162/160K (*)	S	D
12.00R24 160/156G (*)		
16.00R20 173G (*)	S	S
16.00R20 173G (*)	S	
24R20.5 176F		S
14.00R20 164G (*)	S	S
14.00R20 164/160G (*)	S	D
395/85R20 168G (*)	S	
525/65R20,5 173F		S
395/85R20 168G (*)	S	S

S single

D double

(*) Mandatory with 9 ton front axle load.

Other tyres available, subject to the Astra technical office approval.



PNEUMATIC SYSTEM

Two-cylinder 630 cc compressor, APU (Air Processing Unit) that includes: regulation valve set at 10.3 bar, drier, 4-way safety valve, pressure reduction valve for parking circuit and services, 3 air tanks, capacity 30 litres + 2 with 20 litres.

ABS system and EBL (Electronic Brake Limiter).



BRAKES

Front and rear "duo-duplex" self-adjusting wedge type brakes with automatic play take-up.
Total net braking surface 12.058 cm².
ABS + EBL system.

Service brake: Pedal controlled air brake, acting on all wheels.

Solo vehicles: two independent circuits, one for 1st and 2nd axle, one for 3rd and 4th axle; 1st category wheels antilock system.

Towing vehicles: three independent circuits, one for 1st and 2nd axle, one for 3rd and 4th axle and another for the trailer; 1st category wheels antilock system.

Emergency brake: Incorporated in service brake.

Parking brake: Mechanical spring-type with pneumatic control acting on 3rd and 4th axle wheels.

IVECO BRAKE TURBO engine brake:

HD9 440/480/540 HP braking power 300 kW (402 HP)

On request:

Hydraulic intarder.

1st and 2nd axle immobiliser system.

OFF/ROAD button for excluding ABS for speed < 15 kph.



STEERING

ZF 8099 quadrilateral power steering on front axle wheels with variable ratio 1:22.2/1:26.2 with auxiliary cylinder.

Circuit with main hydraulic pump on engine and emergency pump on gearbox.

Steering rods with self-lubricating joints.

Height and inclination mechanical adjustable steering wheel.



SERVICE DATA(I)

Engine oil sump and filters	28 (+2,5)
Gearbox oil	14,5
Power steering oil	18
Cab tipping oil	1
Clutch circuit oil	0,5
Integral PTO oil	3
Transferer oil 86.44-86.48	6,5
Transferer oil 86.54	13
Front axle with final red. oil	6,5
Intermediate axle with final red. oil	27
Rear axle with final red. oil	16
Cooling system water	33
Diesel	300



ELECTRICAL SYSTEM

Voltage: 24 V

Alternator generator 90 A - 28 V (2520 W).

Accumulators: 2 in series, 170 Ah.

Starter motor 24 V 5,5 kW.

Mechanically controlled electrical circuit breaker.

Anti-block system ABS with 4-conduits and 4-electric valves electronic system.

Phonic wheels and sensors on 1st and 3rd axle.

1 electrical joint 7-pole (ISO 7638) for trailer ABS (if applicable).

1 electrical joint 15-pole (ISO 12089-4091) for trailer lighting (if applicable).

Offset trim lights.

Electrical provision for outfitters.

Provision for diagnostics.

Provision for radio/cb (without speakers)

Glow plug for cold start.

On request:

225 Ah accumulators;

Reverse alarm.



CAB

Standard white short cab (AD/HD) built in galvanized pressed steel with hydraulic tilting up to 60°. Cab suspension with 4 helicoidal springs with coaxial shock absorbers and integrated dampers, anti-roll bar and end-of-stroke pads. Tinted electric door windows. Mechanical rear view mirrors, wide angle mirrors and front view mirror. Internal panels completely washable and fireproof. Compressed air quick coupling for cab cleaning. 4-speed ventilation and heating system with air recirculation system. Air suspended 3-way adjustable driver seat with seat belts. Mechanical passenger seat with seat belts.

On request:

RHD.

Air conditioning with anti-pollen filter.

Cab rear window.

Car radio RDS, CD.

Car radio RDS, CD, MP3 Bluetooth technology.

External sun visor.

Extra colour cab: to be specified in the order.

Heated and electric powered rear view mirrors.

Remote controlled and centralized closing of doors.

Roof hatch.

Rotating lights on top of the cab.

White engine hood with central mask in IC575 colour.



INSTRUMENTATION

Dashboard and ergonomic instrument board contain the function buttons and the identification commands.

Indicator lights: engine oil low pressure, alternator charging low, main beam lights, side lights, engine warm-up, rear fog light, hazard lights, tractor turn indicators, trailer turn indicators (if applicable), rotating lights, cab lifted, axles differential locked, differential lock, front brakes air pressure low, rear brakes air pressure low, trailer brakes air pressure low (if applicable), parking brake engaged, splitter (reduction on), slow speeds (1-4/9-12), power take-off on (if applicable) air filters clogged, power steering oil level low, rear view mirrors heated (if applicable), ABS, trailer ABS (if applicable), main steering circuit failure, steering auxiliary circuit failure.

ASTRA Veicoli Industriali

Via Caorsana, 79

29122 Piacenza (Italy)

Tel. ++39-523/5431

Fax ++39-523/59.17.73

www.iveco-astra.com

DEALER

Characteristics and equipment are subject to changes without prior notice.

Technical data and general specifications - validity to be checked according to each individual configuration