

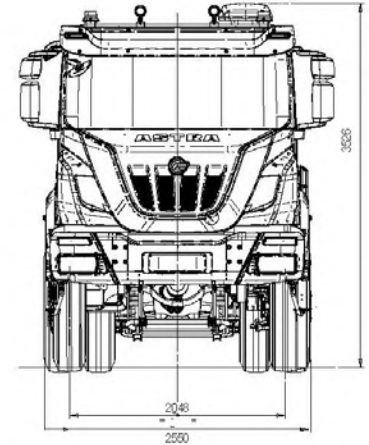

chassis-cab 8x4
HD84.48 11t

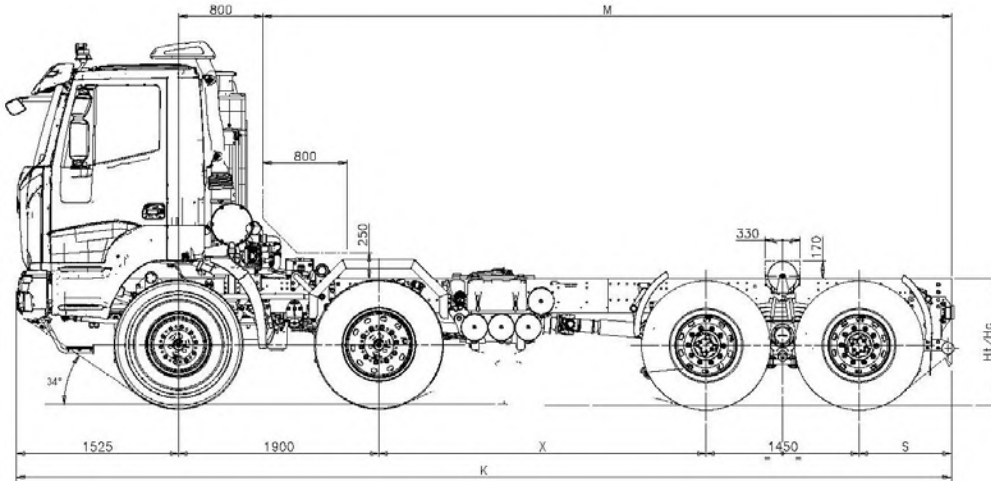

Std configuration with tyres 325/95 R24 tubetype

DIMENSIONS (MM)

X	K	M max(*)	S	H	
				unloaded	loaded
2850	8925	6600	1200	1140	1200
3100	9175	6850	1200	1140	1200

(*) M max.: indicative value to be confirmed by bodybuilder.

WEIGHTS (KG)

X	Distribution net weight(*)			Max technical weight			
	Front axles	Rear axles	Net Weight	Front axles	Rear axles	Gross Vehicle Weight	Gross Combination Weight
2850	8270	4460	12730	22000	40000 (1)	62000 (1)	104000
3100	8345	4425	12770	(1)	42000 (2)	65000 (2)	

(*) Net weight is intended for vehicles in running conditions (driver, 100% of liquids, 90% of fuel) and in basic configuration without optionals and must always be verified during final testing. The above indicated net weights are only estimated and subject to change. For more information please contact Astra Technical Dept.

(1) With tyres 325/95R24, reinforced springs standard and max speed limited to 70 km/h.

(2) With tyres 325/95R24, reinforced springs standard and max speed limited to 40 Km/h. Overload condition. Limited usage according to Payload Management Guidelines.

The data shown are indicative and non-binding. Payload and vehicle dimension data must always be verified during final testing. Do not use the drawing in the present sheet to design the equipment. Astra reserves the right to make any changes at any time and without notice.





ENGINES

FPT CURSOR I3 turbo intercooler euro 3 diesel injection/cycle with electronic unit injection pumps. Single block head, four valves per cylinder, light alloy pistons. Total displacement: 12.882 cm³. Bore for stroke: 135 x 150 mm. 6 in-line cylinders. Water cooling. Dry air filter with safety cartridge. Vertical muffler. **Variable Geometry Turbocharger (VGT)**

Max.power(EEC) 354 KW (480 HP) @ 1900 rpm
Max.torque(EEC) 2200 Nm (224 kgm) @ 1000 - 1440 rpm

397 KW (540 HP) @ 1900 rpm
2350 Nm (239 kgm) @ 1000 - 1690 rpm



GEARBOX

Automated **ASTRONIC ZF 16S2630TO** with integrated Intarder, Ecosplit 4 technology gearbox with servoshift, 16 synchronised forward speeds + 2 reverse.



CLUTCH

Single dry plate, diameter 17". Pull type engagement with diaphragm spring. Hydro-pneumatic power steering engagement control, with driven disk wear recovery slave cylinder.



AXLES

FRONT
Reinforced front steering axles, hot moulding in high tensile steel.
Max allowed weight per axle 11 ton.

REAR
Two driving reinforced axles in tandem, with double reduction. Max allowed weight per axle 20+20 ton. Interaxle and cross-axle differential lock. Tandem linked to the chassis by reaction rods with silentblocks.
Available rear-axle ratios: 1:6,18 -1:6,21.



SUSPENSIONS

FRONT
Reinforced parabolic springs, 4 leaves 26x90 mm, with hydraulic shock absorbers. Stabilizer bar on 1st and 2nd axle.

REAR
Reinforced parabolic springs, swivelling on central pin: 5 leaves 40x100 mm. Stabilizer bar on 3rd and 4th axle.



CHASSIS

Special steel with high tensile strength limit, two flat and parallel side members (width 820 mm.), C section (320x90x10+6mm), cross members bolted to the frame. R.B.M. (Rail Bending Moment): 300.120 Nm. Steel front bumpers with headlamp protection grids, front maneuvering hook, rear underrun bar, rubber mud-guard 2nd axle, steel fuel tank capacity 300 litres.



TYRES

FRONT: 325/95 R24 Single tubetype
REAR: 325/95 R24 Twin tubetype
Spare wheel on the chassis.

The installation of other tyres is subject to approval by Astra technical office



PAYLOAD MANAGEMENT GUIDELINES

To maximize Productivity and insure Durability, the vehicle can operate with higher GVW than target 62 ton, reducing the speed, according to the following table:

GVW	62 [ton] (max Payload)	62 – 65 [ton] (10% overload)	65 – 69 [ton] (20% overload)	higher than 69 [ton]
% di use	50 % (*)	40%	10%	NEVER
max speed [km/h]	70	40	15	0

The data shown are indicative and non-binding. Payload and vehicle dimension data must always be verified during final testing. Astra reserves the right to make any changes at any time and without notice. Technical data and general specifications - validity to be checked according to each individual configuration.



BRAKES

Front disc brakes and rear Z-cam "duo duplex" wedge type with automatic slack adjuster. ABS + EBL.

Service brake: Pneumatic with pedal control, acting on all wheels. Solo vehicles, two independent circuits, one for 1st and 2nd axle, one for 3rd and 4th axle. Anti-lock braking system.

Towing vehicles, three independent circuits, one for 1st and 2nd axle, one for 3rd and 4th axle and another for the trailer. Anti-lock braking system.

Emergency brake: Integrated in service brake.

Parking brake: Manual spring-type with pneumatic control acting on 3rd and 4th axle wheels.

Engine Brake: decompression type with exhaust flap valve and variable geometry turbine effect.



STEERING

ZF 8099 quadrilateral power steering on front axle wheels with variable ratio 1:22.2/1:26.2 with auxiliary cylinder. Circuit with main hydraulic pump on engine and emergency pump on gearbox. Steering rods with self-lubricating joints. Height and inclination mechanical adjustable steering wheel.



ELECTRICAL SYSTEM

Voltage: 24 V
Alternator generator 90 A - 28 V (2520 W).
Accumulators: 2 in series, 180 Ah.
Starter motor 24 V 5,5 kW.
Mechanically controlled electrical circuit breaker.



CAB

Standard white short cab built in galvanized pressed steel with hydraulic tilting up to 60°. Cab suspension with 4 helicoidal springs with coaxial shock absorbers and integrated dampers, anti-roll bar and end-of-stroke pads. Tinted electric door windows. Mechanical rear view mirrors, wide angle mirrors and front view mirror. Internal panels completely washable and fireproof. Compressed air quick coupling for cab cleaning. 4-speed ventilation and heating system with air recirculation system. Air suspended 3-way adjustable driver seat with seat belts. Mechanical passenger seat with seat belts.